

GRUPO HIDRÁULICO TM-25  
 VALVULAS NG-6 (CETOP-3)

EQ 7002  
 07/02  
 Sustituye

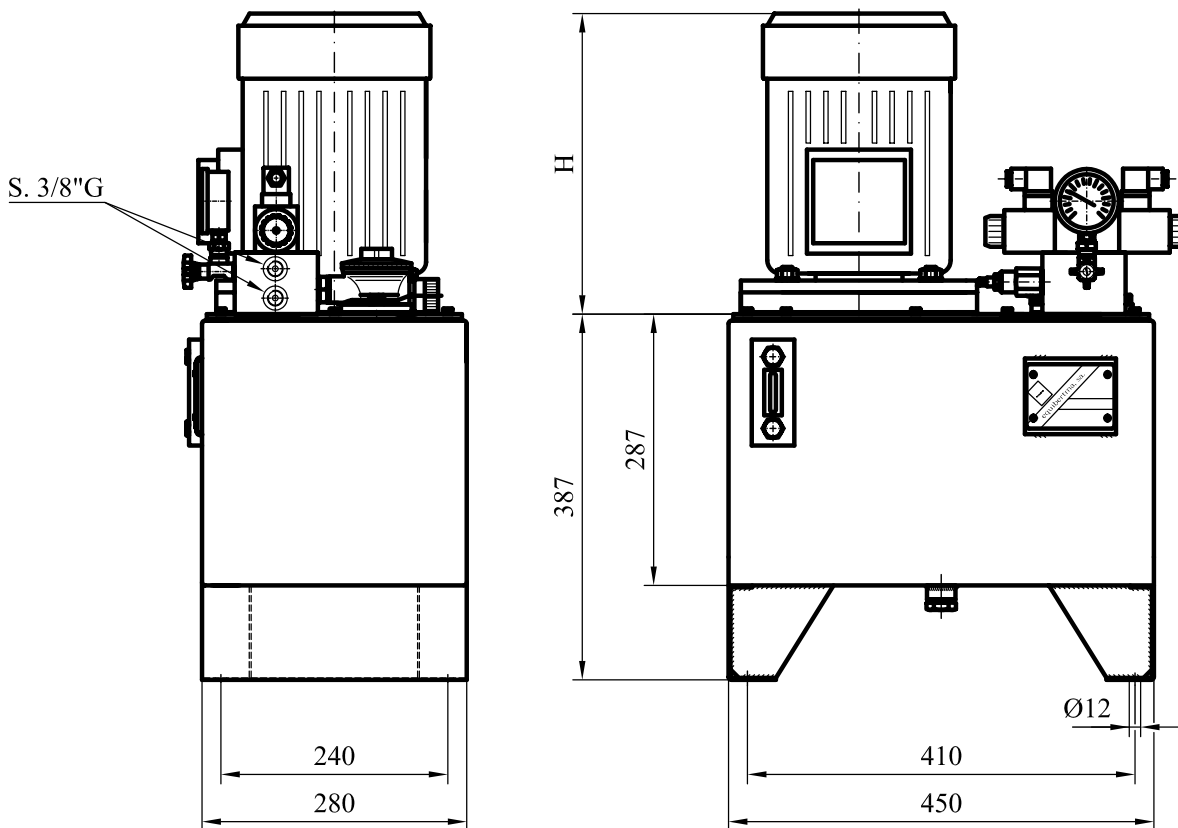

Q a 1500 rpm	POTENCIA EN CV						PRESIÓN EN bar
	0,5	0,75	1	1,5	2	3	
1,7	91	137	183	-	-	-	
3	52	78	103	180	240	-	
5,2	-	45	60	104	138	208	
6,2	-	-	50	87	116	174	
7,3	-	-	42	74	99	148	
H. APROX.	224	245	245	282	282	318	

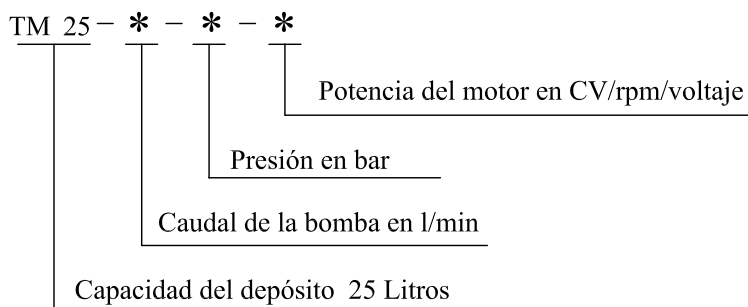

GRUPO HIDRÁULICO TM-25 (BGPS-0638)  
 VÁLVULAS NG-6 (CETOP-3)

EQ 7006  
 07/02  
 Sustituye

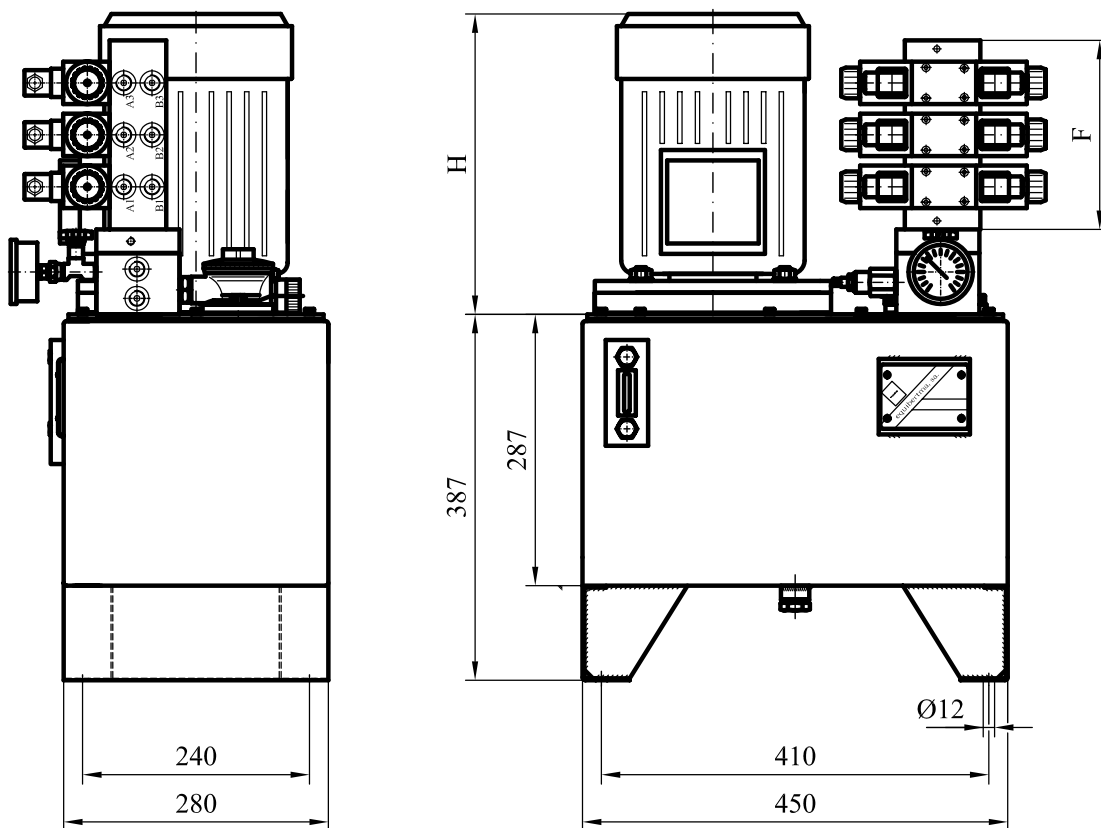

PA10-PA6	F	SALIDAS A y B
BGPS 0638/2	145	3/8"G
BGPS 0638/3	200	
BGPS 0638/4	255	
BGPS 0638/5	310	
BGPS 0638/6	365	

Q a 1500 rpm	POTENCIA EN CV						PRESIÓN EN bar
	0,5	0,75	1	1,5	2	3	
1,7	91	137	183	-	-	-	
3	52	78	103	180	240	-	
5,2	-	45	60	104	138	208	
6,2	-	-	50	87	116	174	
7,3	-	-	42	74	99	148	
H .APROX.	224	245	245	282	282	318	

